

Why 3D?

This 3D guide is designed for people who need to implement 3D CAD throughout their company. You may be a CAD manager, a designer, or an engineer who believes that your company can benefit from 3D – or you may be an IT person who has just received a mandate to evaluate 3D software. Whatever your title may be, part of your job is to get your company up and running on 3D CAD software.

Because a 3D model provides much more detail, designers and engineers can communicate product information and visualize complex parts and assemblies more clearly. Since 3D model data can be transferred to analysis and validation tools and used for CAM as well, it increases the accuracy of results and saves time by eliminating the need to re-create data. Many 3D modeling programs offer features that increase productivity by automating aspects of the design process, for example, by enabling the reuse of existing designs or the quick creation of part families.

For companies that adopt 3D, these capabilities translate into valuable benefits. The main goal is to reduce the time needed to get new products to market. Other objectives include meeting consumer demand for new products, improving product performance, enhancing product quality, and addressing increasingly complex customer requests. In many cases, companies are driven to 3D just to keep up with the competition.

What can 3D do for you?

If you are not familiar with 3D modeling, you can quickly educate yourself – there is an abundance of information on the benefits of 3D. Beyond the general capabilities of 3D software, also research the various products available and their functionality. In addition, talk to as many other companies as you can about their design processes and what software they are using. More than anything else, these people will give you a clear and realistic picture of the benefits and drawbacks of 3D.

How can 3D benefit your company?

Once you have researched the advantages and disadvantages, the next step is to determine how your company can benefit from 3D. To determine this, you need to know more about your company's current design projects and how each department contributes to the system. Make a quick outline of your design and engineering processes. Keep in mind that written processes may differ from the actual ones. Make note of any bottlenecks or other issues where you think 3D could save time or improve efficiency. To find areas where performance can be improved, you may have to do some digging.

Your research should extend beyond the boundaries of your department. Consider where design data goes once it leaves your department. In particular, pay attention to what manufacturing does with design data. When the design goes to production, many of the benefits of 3D will emerge – such as fewer engineering change orders (ECOs), more accurate tooling, as well as reduced waste and rework.

Another effective resource is a data map. Begin by answering the following questions: Does your department send out all design data, or does some data generate elsewhere? In what format does it arrive? Where do you send data? Do other departments use the data? How do they currently access the data? Then consider both internal and external data creators and users. Do you exchange data with suppliers? Are you required to deliver certain file formats to your customers?

As you map your current 2D file types, start thinking about how – or even if – you will transfer your data to your new product. Ideally, your new product will import your native 2D files. Not so ideal is the need to use neutral formats, such as STEP or IGES data translation libraries, as the intermediary between the systems.

Make sure you have a current list of specifications, including processor speed, RAM, and a graphics card, for your department workstations. Finally, do an informal inventory of your department's 3D skills and background. You may be surprised at the number of people who have had experience with 3D CAD, whether through schooling or in a previous job.

Doing 3D right

Once you have done your homework, you will have a clearer picture of what your company can gain from 3D as well as a better idea of what products will suit your needs. It is not too early to start outlining a 3D plan – how you see the 3D design process working, what hardware and software you will need, what level of training is required, and any particular difficulties you anticipate. Remember to rank your goals by priority or timeliness.

Also give some thought to what you specifically want to accomplish with 3D. The more you can quantify your goals, the better you can measure the impact of adopting 3D. You may want to cut a certain percentage of the design errors that make it to manufacturing, for example, or eliminate a number of physical prototypes per project by adopting digital design analysis tools. For new products, you might want to reduce average time-to-market, or decrease product development costs by a target amount.

Picking your product

Functionality is clearly the top criterion for selecting a 3D application, but other considerations can and should factor in to your decision making. By now, you should have an excellent idea of what many of those considerations are. Also look beyond product features to their development history. Examine how often new releases come out, and the proportion of major-to-minor releases. Check out the major new functionality implemented in the past few releases. Does the developer issue prompt and easy-to-install patches to address problems? Also touch base with current users of the product. What problems do they run into? What do they most like about the product? How responsive do they perceive the vendor to be?

Barriers to 3D adoption

Give some thought to who and what are the likely obstacles to 3D within your company. The barriers will likely depend on where you are in the adoption process. If you do not have a set plan for migrating to 3D, the big barrier is probably a lack of support from upper management. If you have management backing and are actively planning to move, resistance will likely come from department members who are uncomfortable with change.

No matter the source of resistance, the following are usually the chief hurdles to overcome:

Inertia. This is the belief that things are working well, so why mess with them? Here, the job is to show how things could be better with 3D. More and more companies are finding that 3D is a necessity to stay competitive in increasingly demanding markets.

Total cost. The cost of a seat of 3D software is only the beginning of your calculations. Be sure to budget for ongoing training and support. One cost that is often overlooked is new or upgraded hardware. Vendors may claim that their software will run just fine on your current hardware, but the reality is that 3D applications require more horsepower than the typical 2D workstation provides. Take a close look at vendors' minimum and recommended hardware guidelines. Try to anticipate the size and complexity of your 3D models. Ask about the workstations used to run the demos you are shown. Also assess the computing needs of any add-on products that you are considering.

"It's too hard." With each release, not only are 3D products getting easier to use, but most vendors have also developed tutorials and tools designed to cushion the change for designers who are comfortable with 2D. Still, any change in software requires time spent on training and getting designers up to speed. Therefore, it is virtually impossible to avoid some dip in productivity.

Selling 3D

Once you've identified the obstacles, you can work on your marketing plan – how you are going to sell 3D to the “road-blocks.” Think about how you can best address the concerns of these people. In the case of upper management, that will likely involve presenting costs and benefits. Be prepared to answer questions such as: Will the long-term gains offset the initial costs and productivity dip? How long until payback? What is wrong with the way we do things now? If you have done your homework, you will be able to present persuasive arguments in support of 3D. However, do not let your enthusiasm lead you into sugar-coating the message or glossing over any drawbacks. Be realistic in estimating both the benefits and the costs of making the switch.

If your concern is the 2D power users, emphasize plans for ongoing training and features in the software that will help them easily make the switch. Think about involving reluctant designers in the planning process or the product testing and review.

Planning your move

Once you gain approval to proceed with the adoption of 3D design, you can flesh out your transition plan. Your goal is to make the transition as smooth as possible. To that end, you want to minimize productivity dips, project delays, wasted effort, and internal disagreement. As you proceed with your planning, be sure to keep the various groups within your company informed of your progress. You want upper management to grow accustomed to hearing from you at regular intervals, not just when something bad happens.

Make good connections. How will you purchase your new software? In most cases, you will deal with a CAD reseller. Evaluate your options. Consider questions such as: What are their areas of specialization? Are they totally focused on MCAD software, or do they serve other markets? If so, what percentage of their business is with manufacturers? Ask about the industry experience of their employees and consultants. If possible, talk to some of their current customers about their experiences. Finally, decide whether the reseller is really listening to your needs.

Pilot project

Most companies start with a pilot project. This is where you test your 3D processes and tools to identify and iron out as many problems as possible. The pilot project should involve a typical new product – one that is representative of the type of designs your company usually creates. Keep the project relatively self-contained so it does not interfere with other work being done, and relatively short-term so you do not delay the full 3D rollout. Pick a low-risk project that can accommodate unexpected delays.

Give a good deal of thought to selecting your design team for the pilot project. They will be the first to get training on the 3D software and, in turn, will help others along the learning curve. Ideally, your design team will also become champions of the new software. You may want to include those with previous 3D experience as well as power users of your current software.

Since you will be relying on pilot team members for feedback on the software and process changes, make sure they will be able to provide a clear and relevant critique as well as suggestions for improvements. You may wish to involve the team in planning the pilot project and in selecting the test project. Remember that the pilot team members most likely will be putting in extra work, so be sure to acknowledge their efforts.

To determine what is working well and what needs to be adjusted, be sure to schedule regular meetings of the entire pilot team. If possible, adjust the processes during the pilot project so you can judge the impact of these changes.

Rethink everything

Most companies that adopt 3D end up changing their work processes. When setting up your pilot project, look back at your data map. What department needs what information, and when? How do you produce your bills of materials (BOMs)? What other applications does your company use, and how do they communicate? How will you get model data to these other users?

Keep 2D?

When companies adopt 3D, 2D does not always disappear. In fact, most companies that adopt 3D continue to use 2D CAD software in some capacity. You may need to deal with legacy drawings that are not worth the trouble to convert to 3D. For tasks such as machine layout, schematics, and conceptual design, 2D may remain the best choice. In addition, you may still need to deliver 2D drawings to suppliers or machinists, or maintain 2D files to meet regulatory requirements.

Once you adopt 3D, try to clearly define the role of 2D in your organization. What tasks do you expect to perform in 2D? What is your plan for legacy data? Will you leave it “as is” and retain a seat or two of your old software to access it, as needed? If you just need to view and print, can you get by with a lower-cost or free application? Many 3D vendors now include a 2D product virtually for free.

Will you convert 2D drawings for use with your 3D software, or just start new projects in 3D? If you have suppliers or customers who want 2D, do you have any leverage for encouraging them to move to 3D? Would there be any benefit to finding a supplier that will accept 3D files?

If you do plan to keep 2D around, be sure to create clear guidelines for its use. You may, for example, use 3D for all new designs, but maintain a 2D process for design modifications. Or, you may identify the existing products you work on the most and convert only those to 3D.

Getting help

Remember that adopting a 3D CAD program is considerably more complicated than upgrading your existing 2D application, or switching from one 2D application to another. To gain maximum benefit from 3D, you should not replace your 2D program with a 3D version. You will also need to adjust your work processes. For example, you need to establish best modeling practices to ensure that models are created in a way that makes sense to everyone. Some of the drawing tricks that work in 2D will result in a 3D model.

To get your company off on the right foot, it makes sense to turn to the experts. Here, your software reseller can help, or can put you in touch with the right contact. Also tap into online resources for your product of choice. Many power users have now started blogs to share their knowledge, and discussion forums are a great way to connect with other designers and engineers. The transition to 3D has been underway now for more than 10 years, so it is highly unlikely that you will encounter a new and unique problem.

Potential pitfalls

A study by the Aberdeen Group, entitled *The Transition from 2D Modeling to 3D Modeling Benchmark Report*, uncovered a few problems that companies did not anticipate when they switched to 3D software. The main challenges were slow performance with large and complex models and difficulties managing CAD relationships. If you have done your hardware homework and upgraded to systems designed for 3D work, however, you should have no problems with slow model performance. Nonetheless, the pilot project is the ideal time to evaluate how complex your products become when modeled in 3D.

Training

Training becomes a top concern for companies that decide to move to 3D. Some 2D CAD designers resist the switch to 3D because 3D solid modeling requires a very different approach than does 2D CAD design. For many, 3D design is more intuitive and easy to master.

Although long-time 2D designers may be reluctant to give up their hard-earned expertise, you may be surprised by how many recognize the limitations of 2D design. As a result, they are eager to expand their experience by learning a new tool. Indeed, some may already have started learning 3D on their own time, as that is the clear direction for the future.

When comparing 2D and 3D, there is a notable difference in the way CAD managers view training and experience in the hiring process. Managers running 2D software tend to be focused on finding applicants with experience in that particular application, right down to the version number. They are also interested in ways to evaluate candidates to ensure their training and experience translate into effective and efficient use of the software. Managers running 3D software are not nearly as concerned with software-specific background and expertise. Instead, they focus on design and engineering ability. As one engineering manager put it, "I look for outstanding product designers. I can teach them the software."

Take some time to sketch out a training plan, keeping in mind that training should be an ongoing, budgeted expense. Remember to anticipate the need for additional training beyond the initial startup sessions. The good news is that there are now more training options than ever before, so you can tailor a plan that fits your needs and budget.

The first training resource to examine is the 3D software itself. How will the software help with the learning curve? Is the interface clean, simple, and easy to understand? Does it provide tutorials, tool-tip explanations, context-sensitive help, and other aids? Spend some time with these features to check that they are easy to use, especially for someone new to the product. Interestingly, many of those who have made the switch to 3D report that the biggest training obstacle is not learning to "think in 3D," but rather to figure out how to do what needs to be done – that is, finding the tools for the tasks. Often, you can customize menus and toolbars to help with this process.

Beyond the product, be sure to evaluate what resources are available through your reseller and through other outlets. Also assess the availability and costs of different types of training: classes (on-site vs. off-site), self-paced learning tools, and online webinars. Also consider less formal learning avenues, such as user groups, conferences, and discussion forums.

As much as possible, tailor training to the needs of individual designers and to the needs of your company. Generic one-size-fits-all classes are useful only in the very early stages of 3D adoption, when the goal is merely to familiarize engineers with the basics of the application.

One more note on training: Periodically check to ensure that your investment in training is paying off. You can do an occasional model check to make sure your designers are building good models. This also will alert you to areas where further training is needed. You may also want to look into some of the training management tools provided by vendors of training materials. These allow you to keep tabs on who has completed tutorials and other lessons provided by the vendor.

Beyond CAD

In planning their transitions, companies should anticipate the need to manage their 3D data. The ability of a 3D model to include much more information about the product is also one of its drawbacks: managing all the data associated with a 3D model becomes a challenge. Many 3D CAD applications come with built-in basic data management capabilities. In many cases, those tools may be sufficient to start with. Still, it is best to anticipate your needs and plan accordingly.

Look for the ancillary applications that will yield the biggest payback in terms of time and cost savings. In some cases, that could be areas such as new product development or engineered-to-order departments, where speed is at a premium. Also look for repetitive tasks or processes – perhaps you have engineers who perform finite element analysis (FEA) or computational fluid dynamics (CFD) analyses on multiple design iterations. Be aware of bottlenecks caused by the need to remodel or reconfigure product data. Do those engineers need to rebuild the product in order to analyze it? Perhaps the design department needs to re-create what the industrial designers send in order to continue work on the new product, or maybe the CNC operator could create models from the 2D drawings provided.

3D modeling is just the beginning. The payoff comes when you can extend your modeling data beyond the engineering department. The ability to reuse rather than re-create the data can save countless hours.

One advantage to today's 3D CAD products is that most offer built-in basic tools for such tasks as analysis, data management, motion simulation, and design automation. This gives you the opportunity to try such programs for free to see if they have a place in your work processes. On the flip side, what comes included may not be full-featured enough to handle your needs. Again, prioritize your needs. Which tasks are important enough to require a more robust add-on application, and which can be relegated to the in-the-box tools?

There are a few tools that just about every company can benefit from. For example, you will need a data management application to help you keep track of complex part and assembly configurations. This tool will also make it easier to reuse your 3D data, and also will allow multiple people to work on the same model without causing problems.

Also worth considering are the many 3D part libraries available online or on CD-ROM. Many vendors now offer CAD-ready 3D models of their stock parts. Millions of parts, such as bearings, fasteners, gears, and bushings, can be downloaded, usually in native CAD file formats. Not only do you save the time required to model such parts, you also acquire all sorts of data about the part – including model number, manufacturer, and size. This can prove valuable in downstream applications.

Top-tier tips

By now, you should be ready to make the move to 3D. Though switching to 3D may seem daunting, keep in mind that thousands of companies have already done so successfully. It is easy to find stories of customers who are thriving with their new 3D modeling software, but no company is on record for unplugging its 3D workstations and going back to 2D.

The Aberdeen Group, in the report mentioned earlier, set out to learn how top-performing companies use 3D to gain their competitive edge in such areas as time-to-market and product development costs. They found five traits that set apart the top companies. We have already discussed the need to adopt new hardware to support the demands of 3D modeling software, and have touched on some of the other traits. You may want to try to incorporate these other tips in your transition plan:

- 1.** Remember that engineers use 3D modeling tools – there is no separate drafting team. They remain in closer touch with their designs when they are doing the actual modeling. If your current organizational structure has separate design and drafting groups, you might look at ways to eliminate that split when you rethink your processes for 3D. However, such a move likely will entail a major restructuring, which may make it more difficult to sell to management, not to mention those affected.
- 2.** Document design deliverables in electronic form. This means eliminate paper as much as possible. Start your designs electronically, and document them electronically.
- 3.** Deploy the extended design and downstream capabilities of 3D modeling. As noted earlier, much of the benefit of 3D comes from beyond the engineering department. You can take a gradual approach by first using any built-in capabilities, then adding on in areas where you can derive additional benefit. Periodically assess how you are using 3D modeling data downstream and what else you could be doing.
- 4.** Check to make sure 3D is delivering on its promise. Occasionally check models to make sure they follow good modeling practices and use as many existing parts as possible. Another metric to watch is how long it takes to find existing designs. The Aberdeen Group suggests formalizing a model quality check at design release. This ensures that you check models on a regular schedule and catch any problems before the design data is released downstream.

Item 4 is a good reminder that your transition to 3D does not end when the software is installed and your designers are trained. You need to make sure 3D is delivering what you expected. Keep in mind the goals you came up with early on in the process, as well as any cost justifications you produced. Use those to gauge the success of your 3D adoption and to fine-tune processes, if required. The periodic model checks will also help pinpoint any problem areas. Even when you do reach your goals, it is a good idea to continue to monitor your 3D processes so you can promptly address any problems.

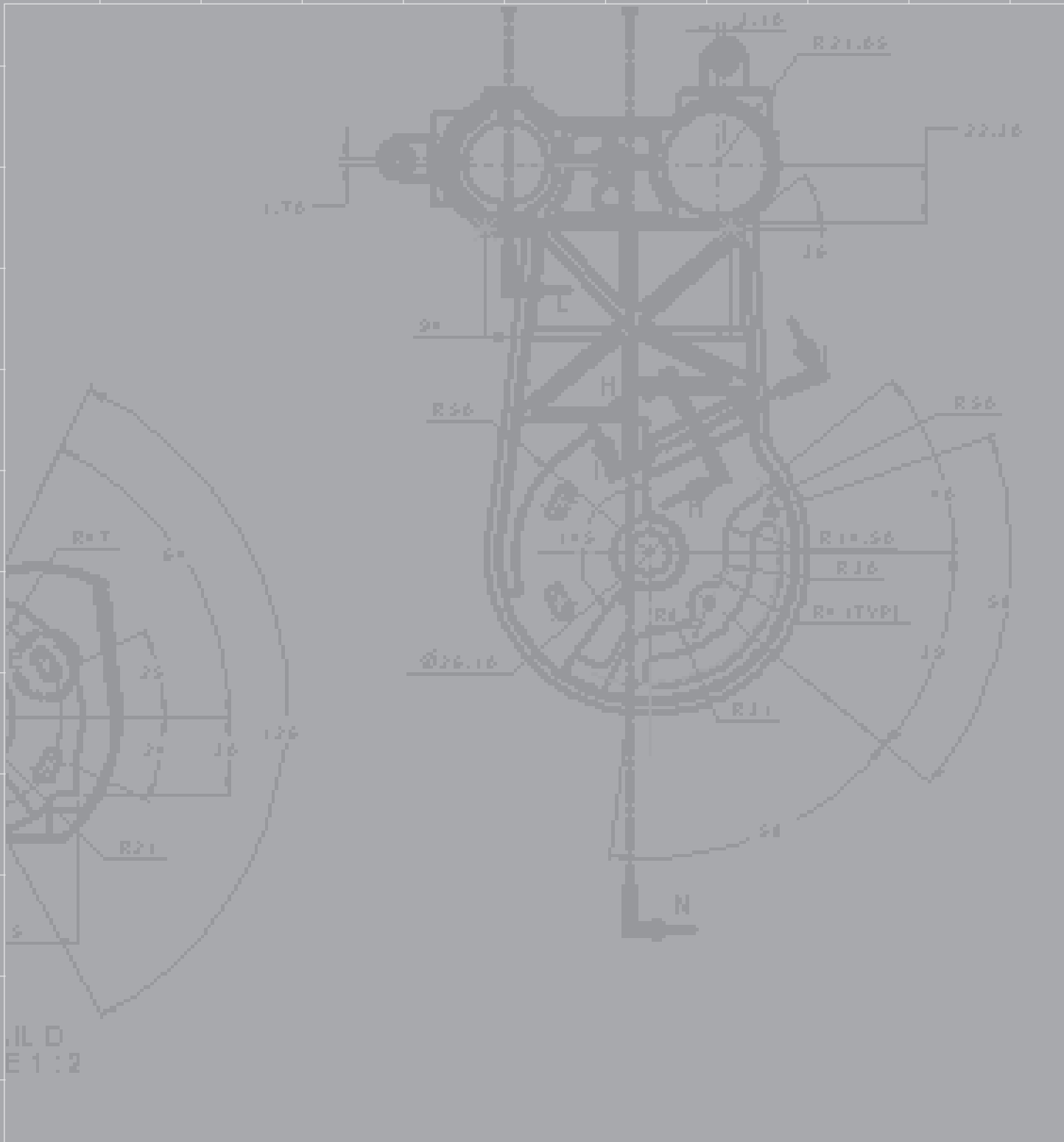

FILED
E 1 : 2

CAD Manager's Guide	
	Dassault Systèmes SolidWorks Corp. 300 Baker Avenue Concord, MA 01742 USA Phone: 1 800 693 9000 Outside the US: +1 978 371 5011 Email: info@solidworks.com
	www.solidworks.com